



SHADOW

ALL-ELECTRIC LABEL PRINTER APPLICATOR

L&C

LABELING
& CODING

SHADOW

ALL-ELECTRIC LABEL PRINTER APPLICATOR

THE EVOLUTION OF UPTIME

Print and apply or pre-printed labeling automation solutions that elevate manufacturing, material handling, and supply chain operations for a better bottom line.

UNPACK. PLUG IN. APPLY.

One of the lowest cost print and apply systems on the market, the Panther Shadow print and apply label automation system is an entry level, on-demand labeling solution.

The Shadow can be unpacked, set up, and working within minutes. It is literally as easy as setting the unit on a table and plugging it in. For greater integration within your operations, the Shadow can also be configured on a stand and rolled up to a conveyor for top and side application of labels.

The Shadow allows the user to print and apply a label instantly. Unlike "loose-loop" systems, the label printed on the Shadow is immediately available for application as there are no labels queued up.

An ideal solution for labeling in work cells, the Shadow is easily integrated with scale heads, barcode scanners, WMS, and ERP systems. And the built-in auto tamp feature means ZERO user adjustments outside of the printer's settings.



No matter what you're labeling – products, packages, pallets, or polybags – Panther features effective labeling automation solutions that help your operations:

INCREASE THROUGHPUT

Faster fulfillment speeds within the same or smaller footprint.

REDUCE EXPENSES

Our lowest-cost robot eliminates your highest labor expense (turnover, onboarding, and training).

DECREASE WASTE/LOSS

Mitigation of waste and loss due to human error or outdated manual processes.



100% electric system, reducing operational expenses by requiring no compressed air.



Labels printed on the Shadow are immediately available for application, as there are no labels queued up.



Shadow with optional stand for top or side label application solution.



OEM SATO print engine capability

FEATURES

Additional Features

- Print engine configurations: SATO
- Maximum stroke length (from bottom of Shadow base)
 - SATO: up to 22"
- Label roll accommodation
 - SATO: 10" OD
- Auto-tamp product contact sensing
- Push-button print request

Customized Options

- Multiple configuration options:
 - Tabletop (standard)
 - Stand mount, top apply
 - Stand mount, side apply
- Foot switch
- RFID configuration
- Wireless Ethernet module

SPECIFICATIONS

Dimensions

- SATO: 17" (w) x 38.3" (h) x 25.7" (d)

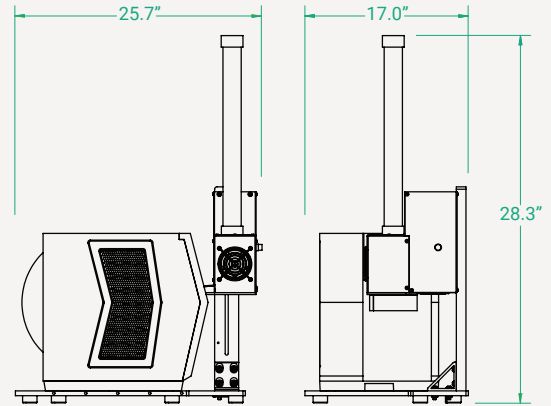

Electrical

- Input: 115-240 VAC @ 5.0 amps 50/60Hz single phase
- Includes power cord

Print Engine

- Print Engines: SATO or Toshiba
- Print Method: Thermal Transfer or Direct Thermal
- Print Width: 4" maximum | 1" minimum
- Print Length: 8" maximum
- Print Resolution: 203, 300, or 600 dpi (600 dpi not available for all print engines)
- Media Supply: 10" OD (SATO)
- Communication: Serial, Parallel, E-Net, Wireless E-Net, USB

Applicator

- Maximum Reach (from bottom of Shadow base)
 - SATO: up to 22"

APPLICATOR CONFIGURATIONS



TAMP

A straight tamp, linear applicator for top and side label applications – stroke length up to 22".



Labeling automation solutions from Panther Industries are engineered to provide reliable operation with simplified maintenance. We understand that 100% uptime is critical to your operations, so our products are designed to run (and run). Our flexible systems feature multiple application methods and are easily integrated and commissioned into your operations.

To learn how labeling automation solutions from Panther Industries will benefit your company's bottom line, contact a Panther sales representative today.

8890 Barrons Blvd.

Highlands Ranch, CO 80129

T: 800-530-6018

P: 303-703-9876

F: 720-283-9462

Panther.Sales@ProMachBuilt.com

PantherLabel.com